

SS Coils

SS11VL Type

[RoHS Compliant]



- <Features>
- Super low profile : 20.5mm max. (19.5 ± 1 mm)
 - High permeability core realizes high inductance (SS11VL-R type)
 - Best suites for internal power supply of compact adaptor and other thin - cased devices.

Model	Rated current AC(A)	Inductance (mH) min.	DC resistance (Ω /line) max.	Temperature rise(K) max.	Marking	Weight approx. (g)
SS11VL-03550	0.3	55	4.1	45	03 LOT No.	10.5
SS11VL-04350	0.4	35	2.6	45	04 LOT No.	10.7
SS11VL-05230	0.5	23	1.8	45	05 LOT No.	10.5
SS11VL-06180	0.6	18	1.3	45	06 LOT No.	11.1
SS11VL-07120	0.7	12	0.90	45	07 LOT No.	10.8
SS11VL-08083	0.8	8.3	0.74	45	08 LOT No.	9.8
SS11VL-10062	1.0	6.2	0.44	45	10 LOT No.	11.1
SS11VL-11050	1.1	5.0	0.40	45	11 LOT No.	10.7
SS11VL-13035	1.3	3.5	0.28	45	13 LOT No.	10.5
SS11VL-17024	1.7	2.4	0.19	45	17 LOT No.	10.8
SS11VL-22013	2.2	1.3	0.12	45	22 LOT No.	10.4
SS11VL-30006	3.0	0.6	0.06	45	30 LOT No.	9.6
SS11VL-R03820	0.3	82	4.1	45	R03 LOT No.	10.5
SS11VL-R04520	0.4	52	2.6	45	R04 LOT No.	10.7
SS11VL-R05350	0.5	35	1.8	45	R05 LOT No.	10.5
SS11VL-R06270	0.6	27	1.3	45	R06 LOT No.	11.1
SS11VL-R07190	0.7	19	0.90	45	R07 LOT No.	10.8
SS11VL-R08125	0.8	12.5	0.74	45	R08 LOT No.	9.8
SS11VL-R10093	1.0	9.3	0.44	45	R10 LOT No.	11.1
SS11VL-R11076	1.1	7.6	0.40	45	R11 LOT No.	10.7
SS11VL-R13052	1.3	5.2	0.28	45	R13 LOT No.	10.5
SS11VL-R17036	1.7	3.6	0.19	45	R17 LOT No.	10.8
SS11VL-R22020	2.2	2.0	0.12	45	R22 LOT No.	10.4
SS11VL-R30009	3.0	0.9	0.06	45	R30 LOT No.	9.6

- Rated voltage: 250VAC/VDC • Withstanding voltage: AC 2400V (2 sec between lines)
- Insulation resistance: at 500VDC, more than 100M Ω (between lines) • Thermal class: E (120°C)
- Operating temperature range (°C): -25 to T (T=120-temperature rise) • Inductance measurement condition: 1kHz, 1V, KC530

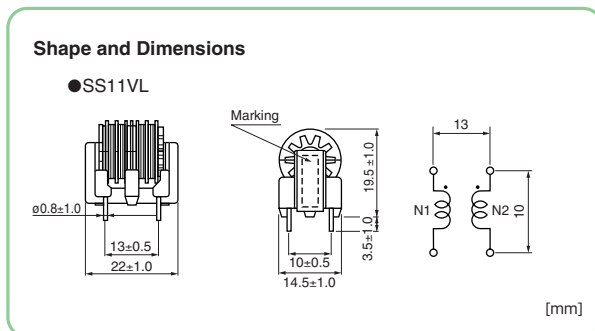

Numbering System

SS 11VL- 03 550

① ② ③ ④ ⑤ ⑥

- ① Series
- ② Core size
- ③ Type (VL : vertical)
- ④ Core Type (R : high permeability core)
- ⑤ Rated current (03 stands for 0.3A)
- ⑥ Inductance (550 stands for 55.0mH)



- All specifications in this catalog and production status of products are subject to change without notice. Prior to the purchase, please contact NEC TOKIN for updated product data.
- Please request for a specification sheet for detailed product data prior to the purchase.
- Before using the product in this catalog, please read "Precautions" and other safety precautions listed in the printed version catalog.

Frequency characteristic

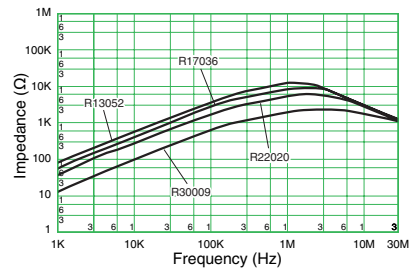
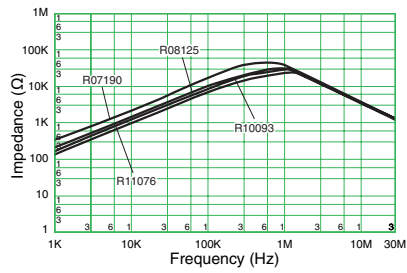
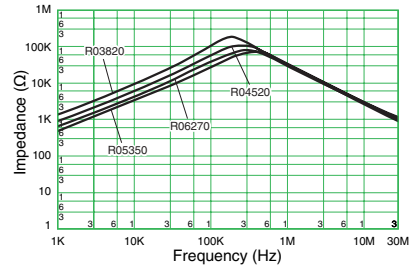
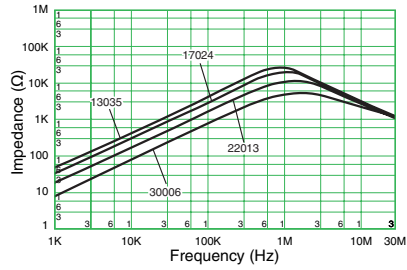
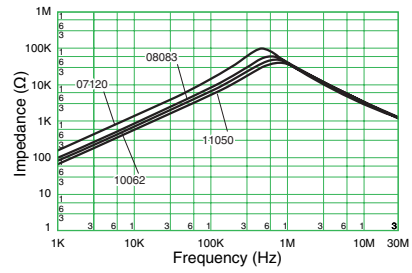
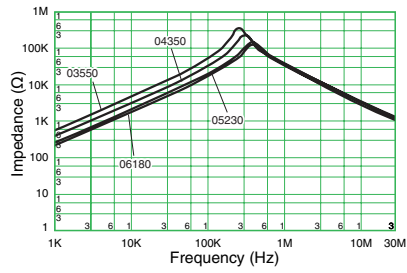

- All specifications in this catalog and production status of products are subject to change without notice. Prior to the purchase, please contact NEC TOKIN for updated product data.
- Please request for a specification sheet for detailed product data prior to the purchase.
- Before using the product in this catalog, please read "Precautions" and other safety precautions listed in the printed version catalog.